

CASAMBI BT-5-CAS

BT-5-CAS

Programador de 5 canales. Funciona con sistema CSAMBI mediante Bluetooth, compatible con Android e IOS. Permite seleccionar colores fijos y escenas de cambios de color. Posibilidad de ON/OFF e intensidad con 2 pulsadores libre de carga (no incluidos).

5- channel programmer. CASAMBI system over Bluetooth. Compatible with Android and IOS. Can select fixed colours and colour-change scenes. Option of ON/OFF and intensity with 2 volt-free buttons (not included).

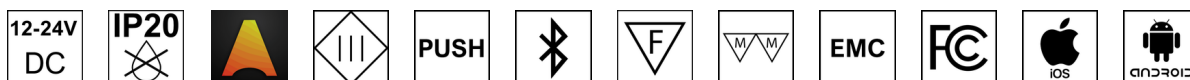

Características técnicas

Technical data

IP	20
Voltaje entarda / Input voltage	DC 12/24V
Voltaje entrada / Output voltage	DC 12/24V
Corriente / Corrent	
Potencia / Power	
Temperatura de funcionamiento / Operating temperature	
Temperatura de almacenamiento / Storage temperature	

Accesorios

Accessories

RP-RGB-150	Repetidor Repeater	125 x50 x 25mm
RP-RGB-360	Repetidor Repeater	87 x 21 x 8,5mm
RP-RGBW-150	Repetidor Repeater	125 x50 x 25mm
RP-RGBW-300	Repetidor Repeater	87 x 21 x 8,5mm
2 x RP-RGB-150	Repetidor Repeater	125 x50 x 25mm
2 x RP-RGB-360	Repetidor Repeater	87 x 21 x 8,5mm

Medidas

Dimensions

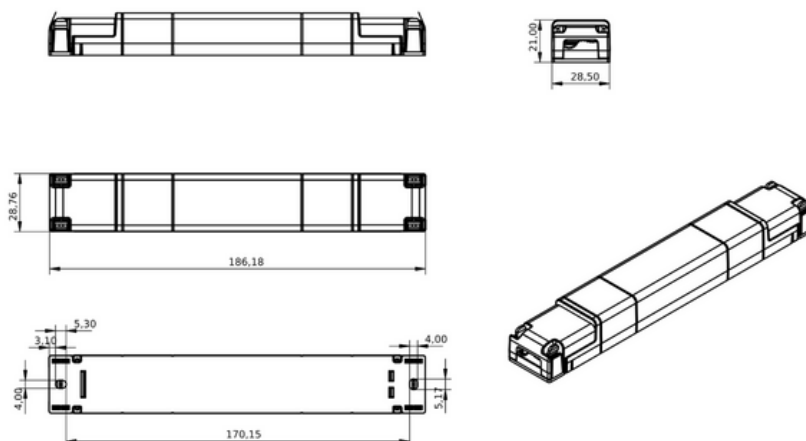

CASAMBI BT-5-CAS

Instalación sin repetidor (Monocolor) Installation without repeater (Monocolor)

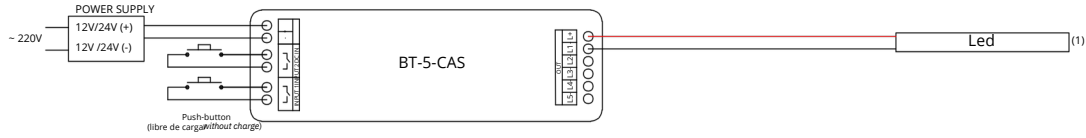

Instalación sin repetidor (DW) Installation without repeater (DW)

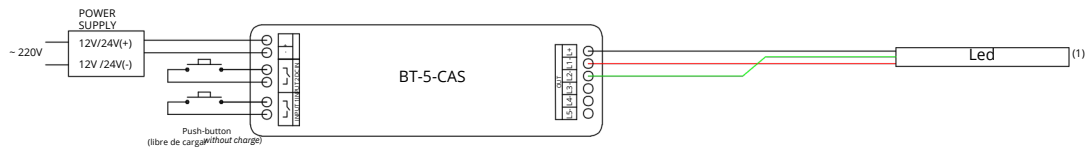

Instalación sin repetidor (RGB) Installation without repeater (RGB)

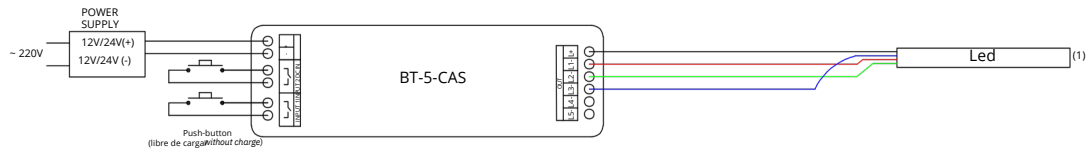

Instalación sin repetidor (RGBW) Installation without repeater (RGBW)

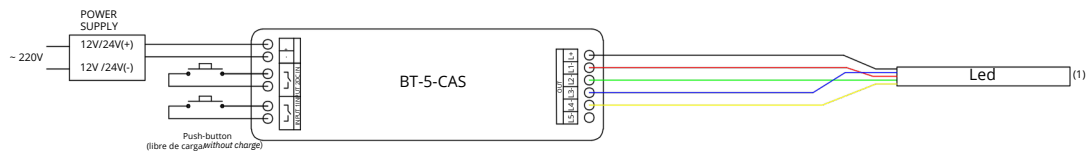

Instalación sin repetidor (RGB+DW) Installation without repeater (RGB+DW)

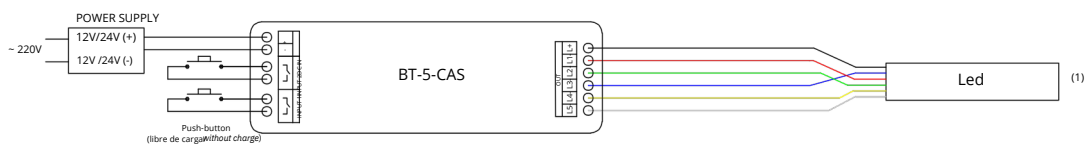

Instalación con repetidores (Monocolor)

Installation with repeaters (Monocolor)

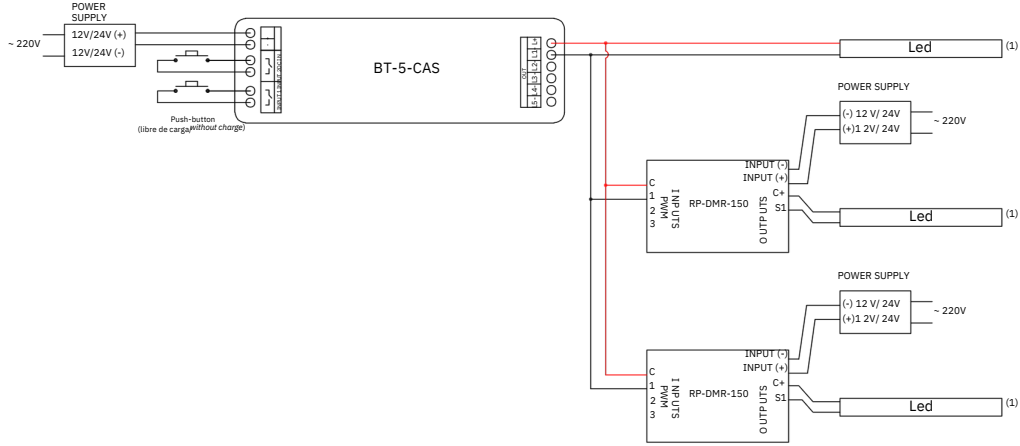

Instalación con repetidores (DW)

Installation with repeaters (DW)

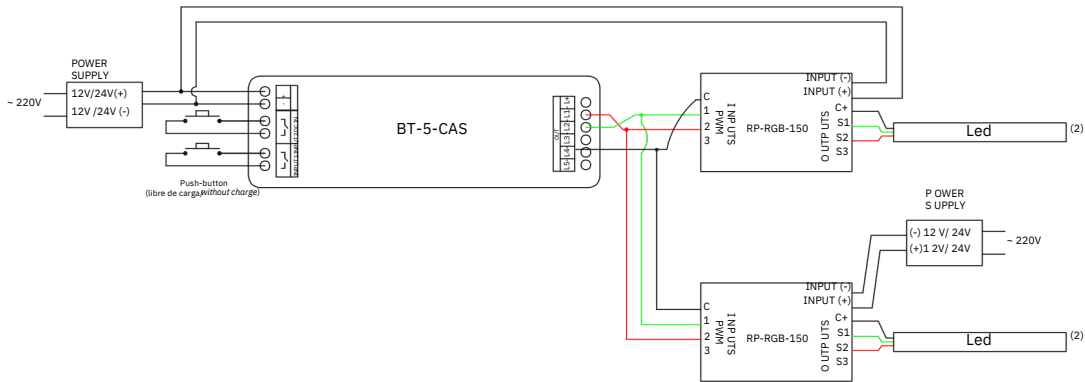

Instalación con repetidores (RGB)

Installation with repeaters (RGB)

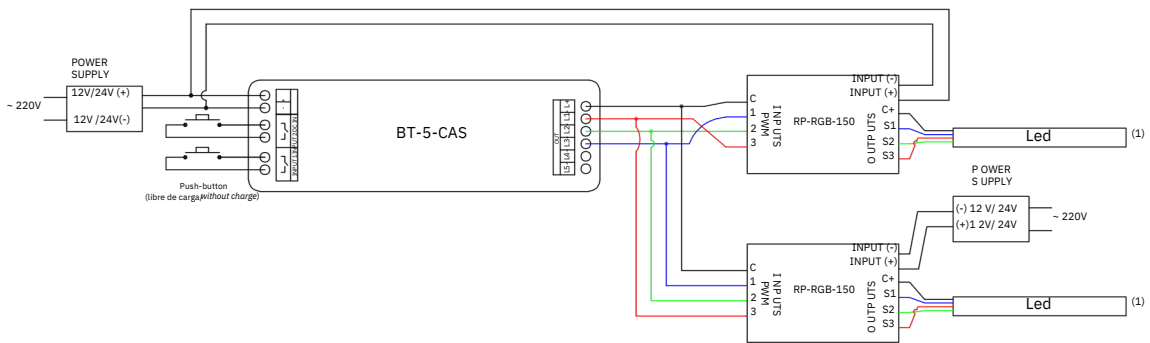

Instalación con repetidores (RGBW)

Installation with repeaters (RGBW)

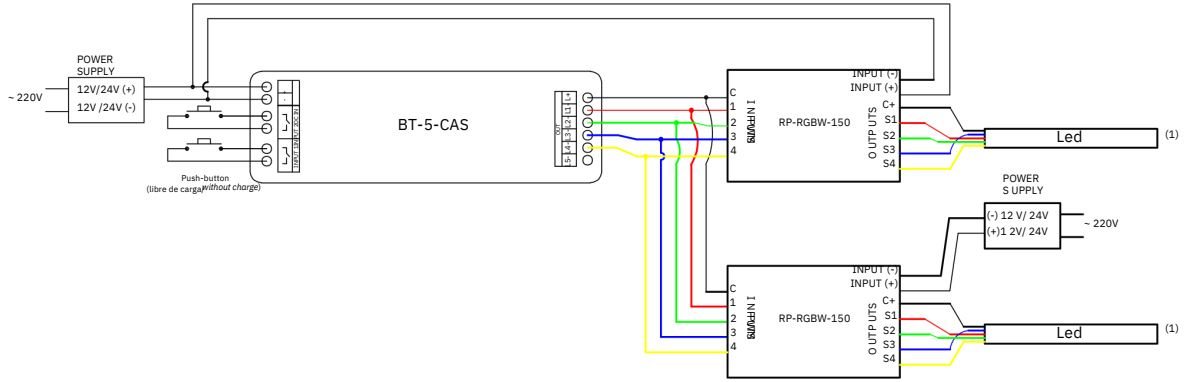

Instalación con repetidores (RGBW)

Installation with repeaters (RGBW)

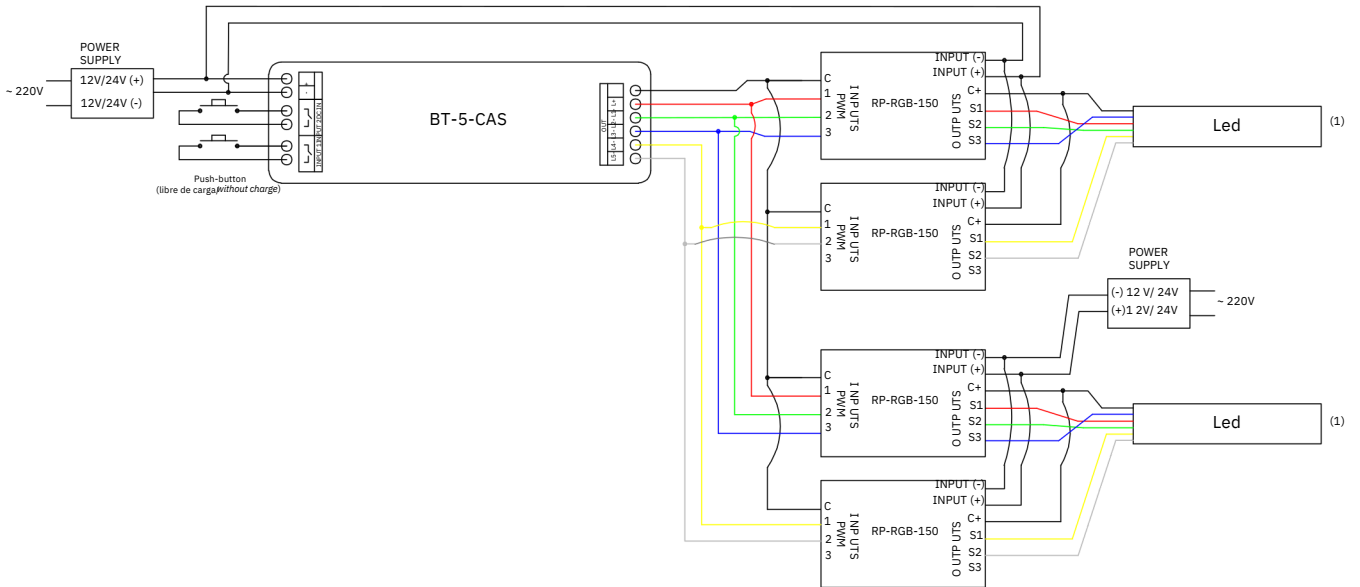

CASAMBI

BT-5-CAS



Advertencias

Warnings

- **La instalación y el mantenimiento del convertidor la deberá realizar personal cualificado.**
 - **Este convertidor no es estanco, en instalaciones de exterior o con humedad deberá ir instalado en cajas estancas.**
 - **La instalación en sitios con buena ventilación prolongará la vida útil del convertidor.**
 - **Compruebe que la tensión de entrada y de salida están dentro de los parámetros indicados.**
 - **Los picos de tensión pueden causar daños en el convertidor.**
 - **Asegure que el cable utilizado en la instalación es de tamaño adecuado.**
 - **Asegure que el cable hace contacto correctamente con el conector.**
 - **Asegure que todas las conexiones de cable y las polaridades son correctas antes de conectar la alimentación.**
-
- The installation and maintenance of the converter must be carried out by qualified personnel.
 - This converter is not watertight, in outdoor installations or with humidity it must be installed in watertight boxes.
 - Installation in well ventilated areas will prolong the life of the converter.
 - Check that the input and output voltage are within the indicated parameters.
 - Voltage peaks can cause damage to the converter.
 - Ensure that the cable used in the installation is of adequate size.
 - Ensure that the cable makes proper contact with the connector.
 - Ensure that all cable connections and polarities are correct before turning on the power.

